



Active and Reactive Intensity Measurements using the Dual Channel Real-Time Frequency Analyzer 2133

by *K. B. Ginn*
Brüel & Kjær

Introduction

Sound intensity is now a well established measurement technique for which the public's interest has been demonstrated by an increasing number of conferences on the topic. The advantages of the technique have been well described in the literature (Ref.[1, 2 & 3]).

A number of systems are commercially available for the measurement of the active intensity i.e. the net amount of energy propagating in a sound field. These systems are typically based on a phase-matched two channel instrumentation where the phase gradient between two closely spaced transducers is measured. Mathematically the active intensity vector component denoted by the symbol I_r is related to the phase gradient by:

$$I_r = \frac{-p_{rms}^2}{\rho ck} \frac{\partial \phi}{\partial r} \quad (1)$$

where $\frac{\partial \phi}{\partial r}$ is the phase gradient of the sound field in direction r , p_{rms}^2 is the mean square pressure, ρc is the impedance of the medium which is the product of the density of the medium ρ and the speed of sound in the medium c

and k is the wave number. Another useful property of the sound field closely associated with the active intensity is the reactive intensity denoted by the symbol J . The reactive intensity is related to the amplitude gradient in the sound field and can be expressed mathematically as:

$$J_r = \frac{-1}{2\rho ck} \frac{\partial p_{rms}^2}{\partial r} \quad (2)$$

where J_r is the reactive intensity vector component in direction r . The simplest, but not the most practical way, to measure the reactive intensity would be to use a sound level meter to determine the pressure gradient from two pressure measurements separated by a known distance. The Dual Channel Real-Time Frequency Analyzer 2133 equipped with an intensity probe can measure both active and reactive intensity directly. An obvious question to ask is how will this extra information help an engineer to deal with a noise control problem. It should be borne in mind that all the acoustical quantities that could be measured are complementary. Measurements of the scalar quantity, sound pressure, can be used to establish the severity of a noise problem. Measurements of the

vector quantities, active intensity and reactive intensity can yield information about the magnitude and direction of propagating and non-propagating acoustical power respectively (Ref. [4]). Active intensity can be used to identify and to determine the sound power of a noise source while other sources are present. Reactive intensity can yield information about the structure of the non-propagating part of the sound field which exists close to a source. It can also reveal the presence of a standing-wave. Reactive intensity is related to the gradient of potential energy in a sound field by:

$$J_r = -\frac{c^2}{\omega} \text{grad } V_r \quad (3)$$

where V_r is the potential energy between two points in the field and ω is the angular frequency $\omega = kc$. At pressure maxima and minima the gradient of potential energy is zero thus J_r also becomes zero in these regions.

Figs. 1 & 2 show what the active and reactive intensity plots look like in front of two loudspeakers operating in anti phase. The distance between the loudspeakers is less than the frequency of interest. The location of the

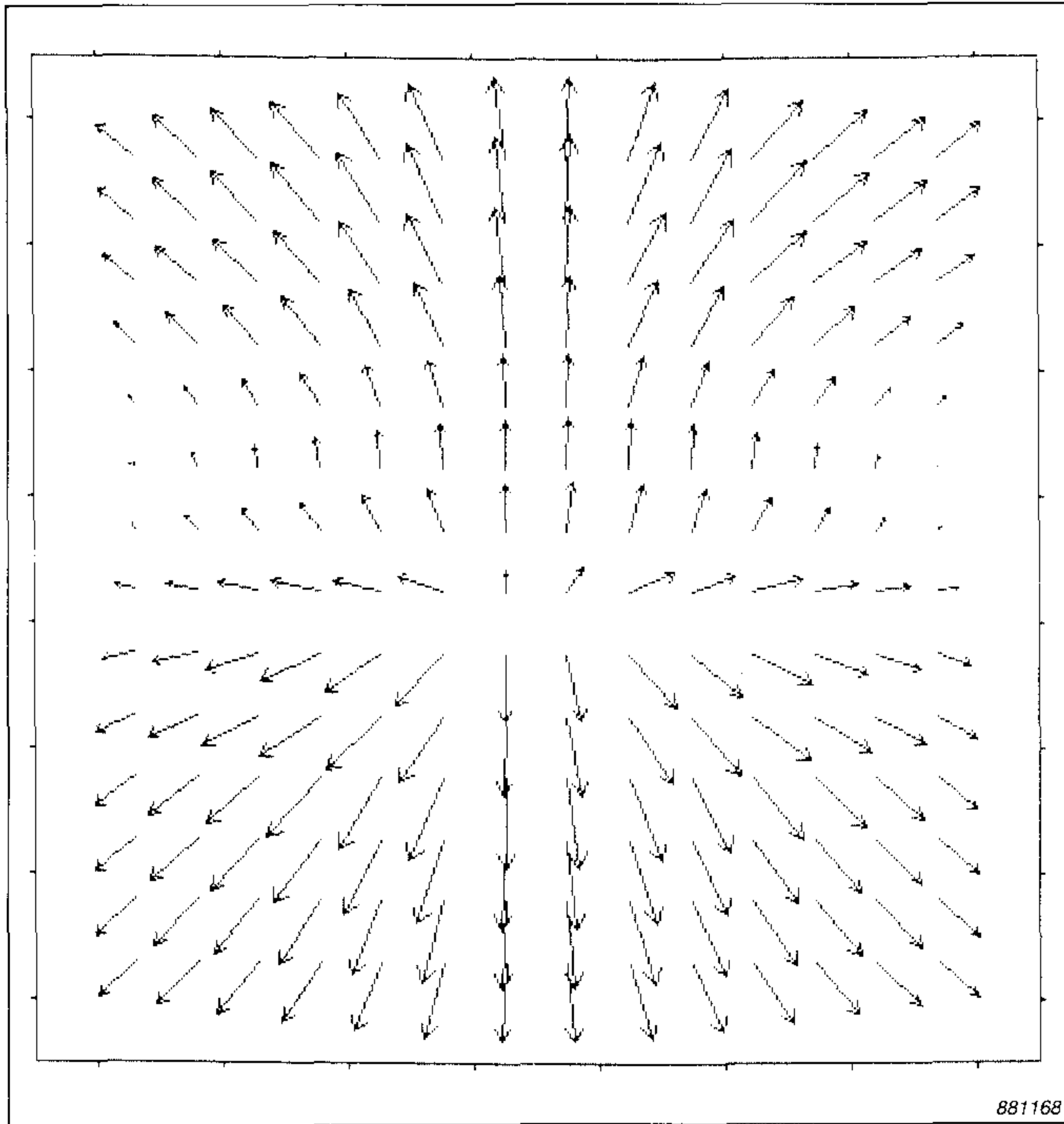

Fig. 1. Active intensity vector plot over two loudspeakers in anti-phase. The location of the loudspeakers is not obvious

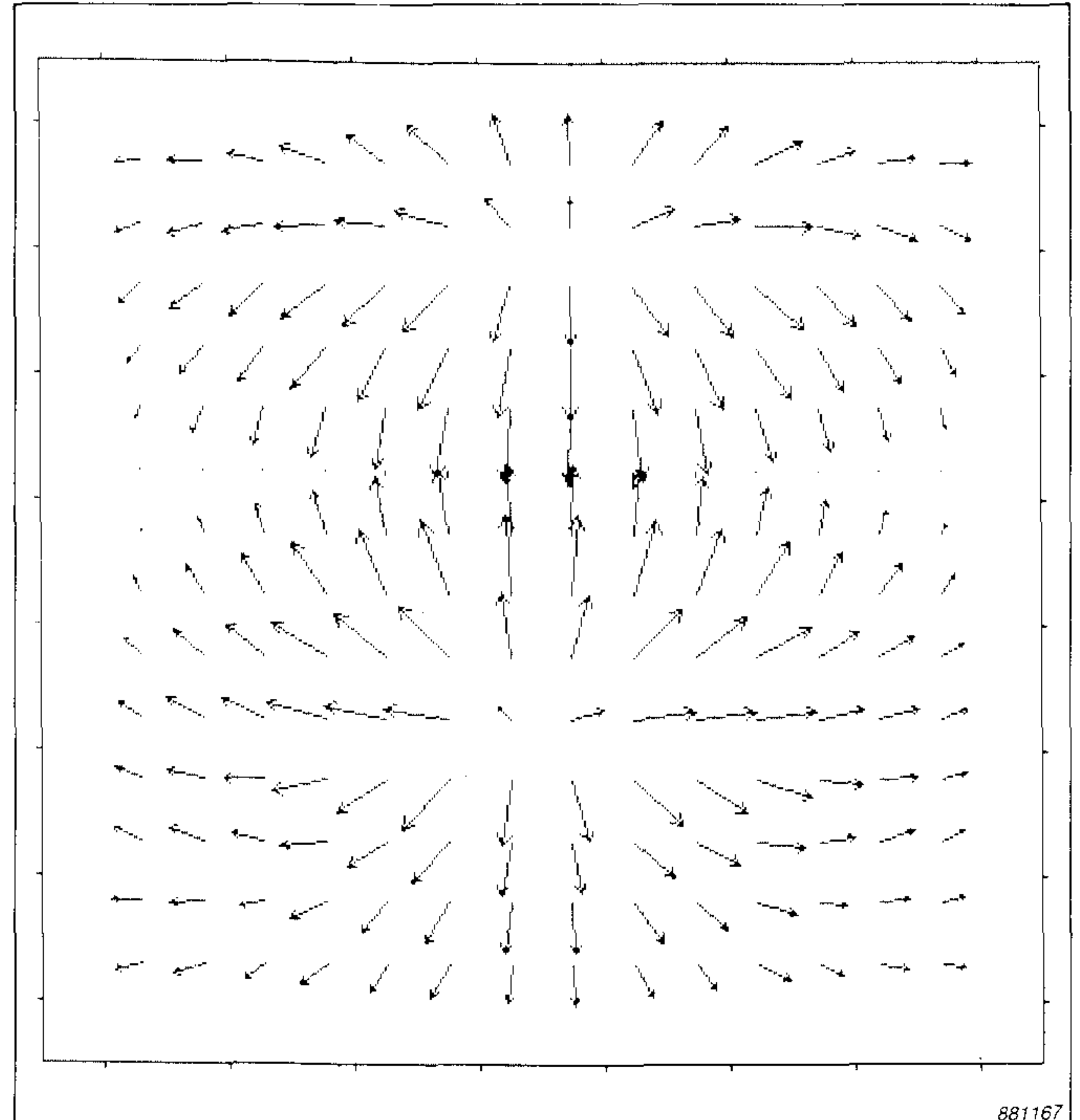

Fig. 2. Reactive intensity vector plot over the same loudspeakers as in Fig. 1. The location of the loudspeakers can clearly be seen

loudspeakers is not evident from Fig. 1, although another mapping of active intensity made closer to the source would reveal more detail. The reactive intensity plot however clearly shows the regions of high pressure in front of the loudspeakers.

Why is this so? It must be remembered that two loudspeakers in anti-phase constitute one coherent source, just as two loudspeakers in phase are one coherent source. The sound fields of these sources however, have a struc-

ture. If the two loudspeakers in anti-phase in the example were perfectly balanced, the vector plots of the active and the reactive intensity would each have two axes of symmetry; one axis passing through the centres of the loudspeakers, the other axis at right angles to the first and positioned midway between the loudspeakers. Whether the active intensity plot would indicate two loudspeakers would depend on the quality of the measurement in the plane of measurement; the closer the measurement is

made to the source, the more likely it is that the loudspeakers would be revealed.

In our example, the lower loudspeaker is slightly more powerful than the upper one. This results the lack of symmetry see in Fig. 1. When one loudspeaker is far more powerful than the other then there would be an energy flow from the stronger to the weaker loudspeaker. In other words, the weaker loudspeaker becomes an acoustic sink; it absorbs some of the

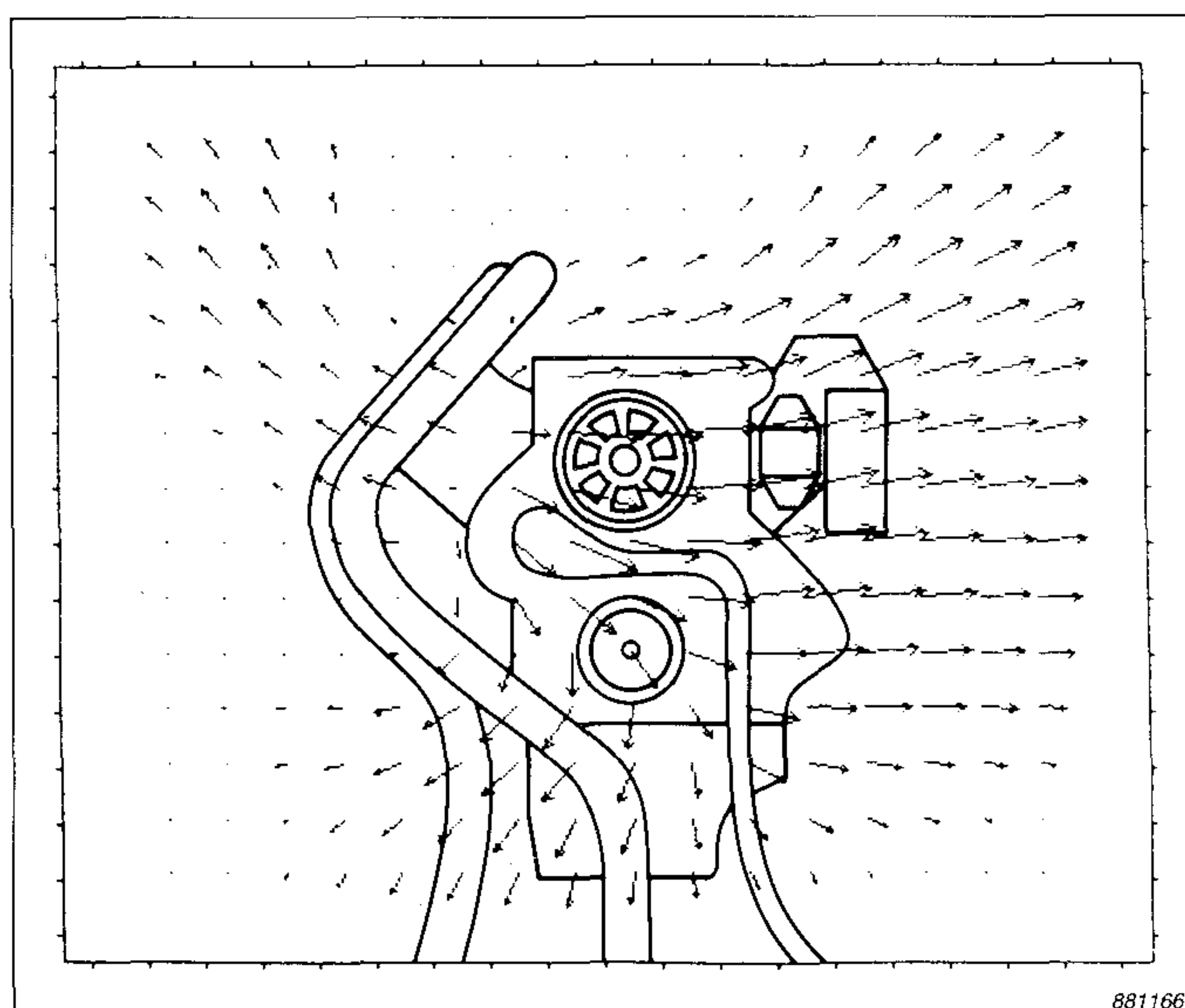

Fig. 3. Active intensity vector plot. 400 Hz third octave band

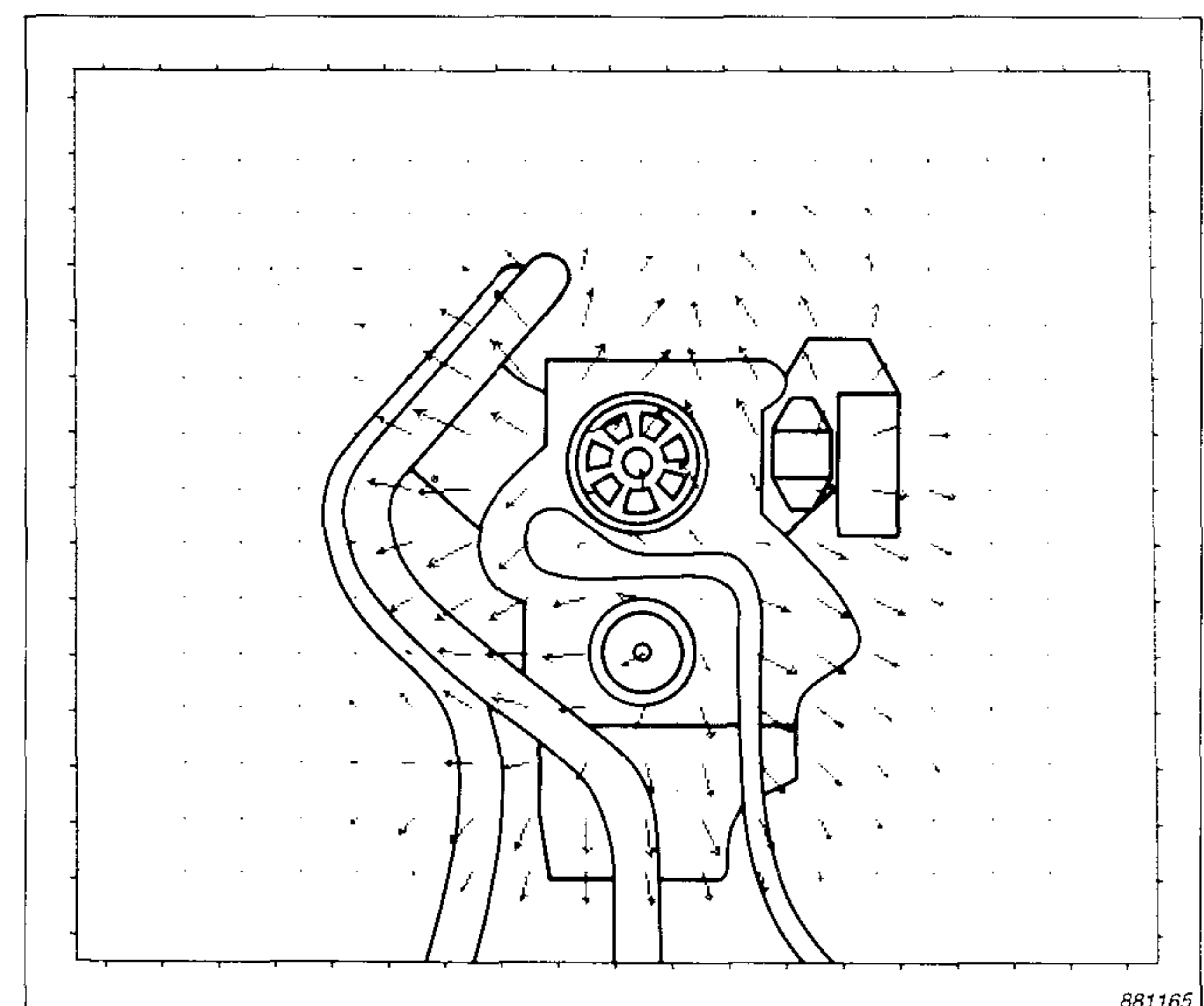

Fig. 4. Reactive intensity vector plot. 400 Hz third octave band

energy radiated by the stronger loudspeaker. This phenomenon is sometimes referred to as an acoustical short circuit. A map of reactive intensity in this case would indicate the position and the relative strengths of the two loudspeakers. This is illustrated in Fig. 2, which confirms the interpretation of Fig. 1, i.e. the lower loudspeaker is the stronger of the two.

Further examples of the use of active and reactive intensity to visualise sound fields are described below where, some results are shown from measurements of active and reactive intensity performed on a diesel engine and also on a motorbike.

Instrumentation

The intensity analysing system consisted of a Dual Channel Real-Time Frequency Analyzer Type 2133 fitted with a Sound Intensity Probe Type 3545 and Remote Control Unit ZH 0354. The system was calibrated using an Intensity Calibrator Type 3541 as described in another Application Note (Ref.[5]). Using a measurement set-up on the analyzer, the active and reactive intensity can be measured simultaneously using formulae based on the finite difference approximation for the particle velocity.

$$I_r = \frac{-1}{2\rho\Delta r} \overline{(p_A + p_B) \int (p_B - p_A) dt} \quad (4)$$

$$J_r = \frac{-1}{2\omega\rho\Delta r} \overline{(p_A + p_B) (p_B - p_A)} \quad (5)$$

where p_A and p_B are the pressures means at points A and B separated a distance of Δr .

Measurements on engine

A grid of 13 by 19 measurement points was defined in a plane situated

at the front end of an 8 cylinder, 14 litre "V" diesel engine. Active and reactive intensity were measured simultaneously in third octave bands at each point in the frequency range 100 Hz to 5 kHz using a linear averaging time of 8 s. The total measurement time including moving the probe from point to point was about 1 hour. The measured data were stored on the analyzer's built-in floppy disc before being processed using a mapping software package.

Vector plots of both active and reactive intensity for the 400 Hz third octave band are shown in Figs. 3 and 4. The plane of measurement is situated some 20 cm from the surface of the engine. The strong radiation of noise seen in Fig. 3 originated from a fault in the left hand cylinder block. The right hand cylinder block is apparently swamped by this radiation. In Fig. 4, however, the reactive intensity plot shows several regions of high pressure; over the left and right cylinder block and in front of the torsional damper. Thus although the left hand cylinder is the major source of noise in this frequency band, it is not the only source.

Measurements on a motorcycle

The contour plots in Figs. 5 & 6 show the distribution of active and reactive intensity close to a motorcycle engine. Active and reactive intensity both indicate that the principal sources of noise in the 1600 Hz twelfth octave band are the crank shaft cover and the exhaust. Note how the reactive intensity maximum corresponds very well with the location of the crank shaft cover. The pressure distribution of Fig. 7 shows that a pressure map also locates the crankshaft cover however the definition is not as great as that obtained using reactive intensity.

Conclusions

This Note shows how a noise control engineer can obtain better visualisation of the complicated sound fields found in practice by mapping both the active and reactive intensity. Basically, an active intensity map yields information about the sound energy flow and thus can be used to determine sound power and to locate sound sources whereas a reactive intensity map can reveal the structure of the sound field i.e. regions of pressure maxima and minima. The measured data can be presented as a vector plot, contour plot, number plot of 3-D plot by the disc based, software program BZ 7021 which runs within the Analyzer 2133, without the need for an external computer.

References

- [1] "Reference literature on sound intensity", B & K publication.
- [2] "Second International Congress on Acoustic Intensity". CETIM, Senlis, Proceedings, France 1982.
- [3] "Sound intensity part 1 and 2", S. Gade, B & K Technical Review, nr. 3 and 4, 1982.
- [4] "Sound radiation and sound field studies using intensity techniques", J. Tichy, Acoustic Intensity Symposium, Tokyo, January, 1987, Proceedings.
- [5] "Calibration of an intensity analyzing system". B & K Application Note.

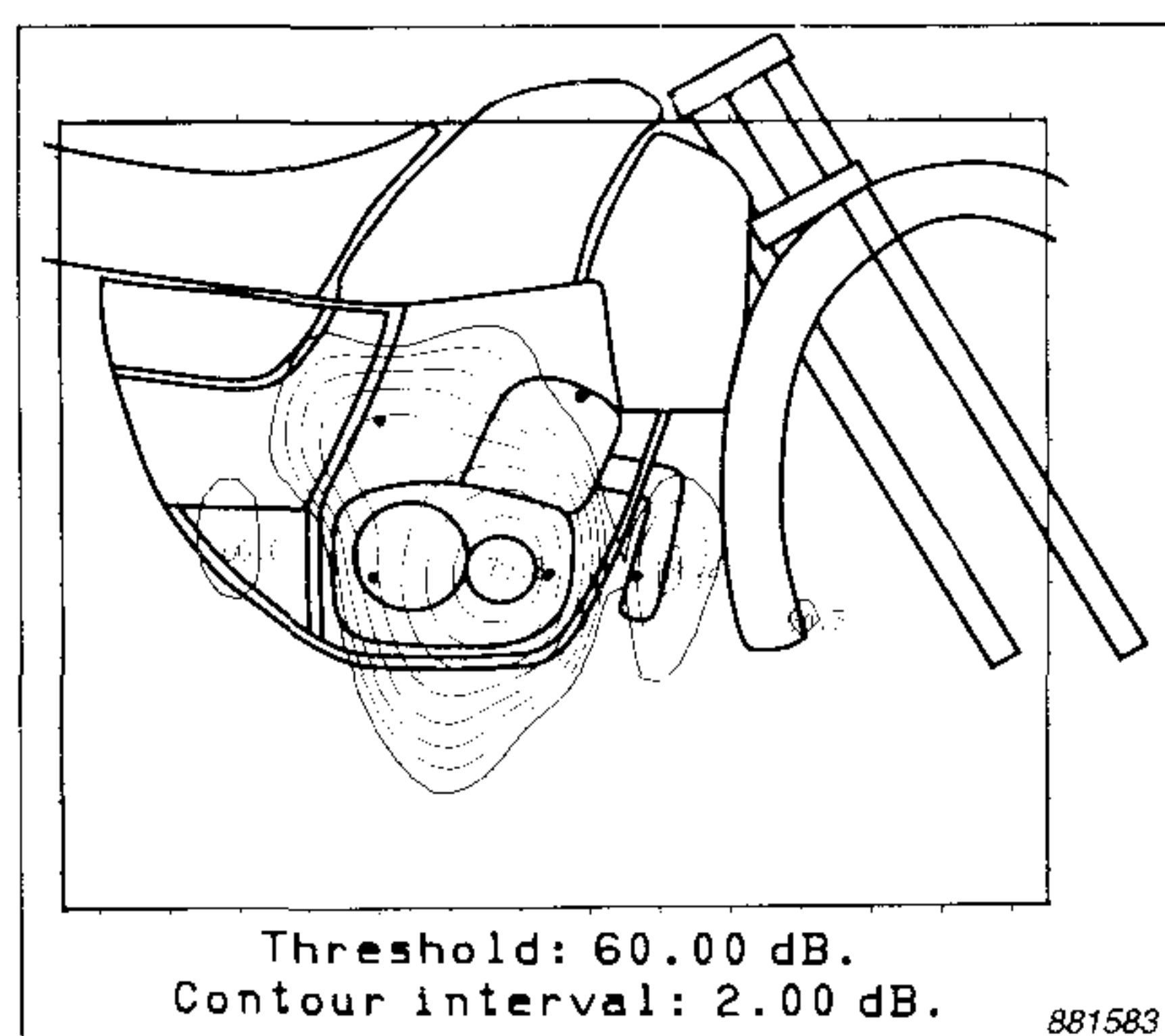

Fig. 5. Active intensity contour plot. 1600 Hz twelfth octave band

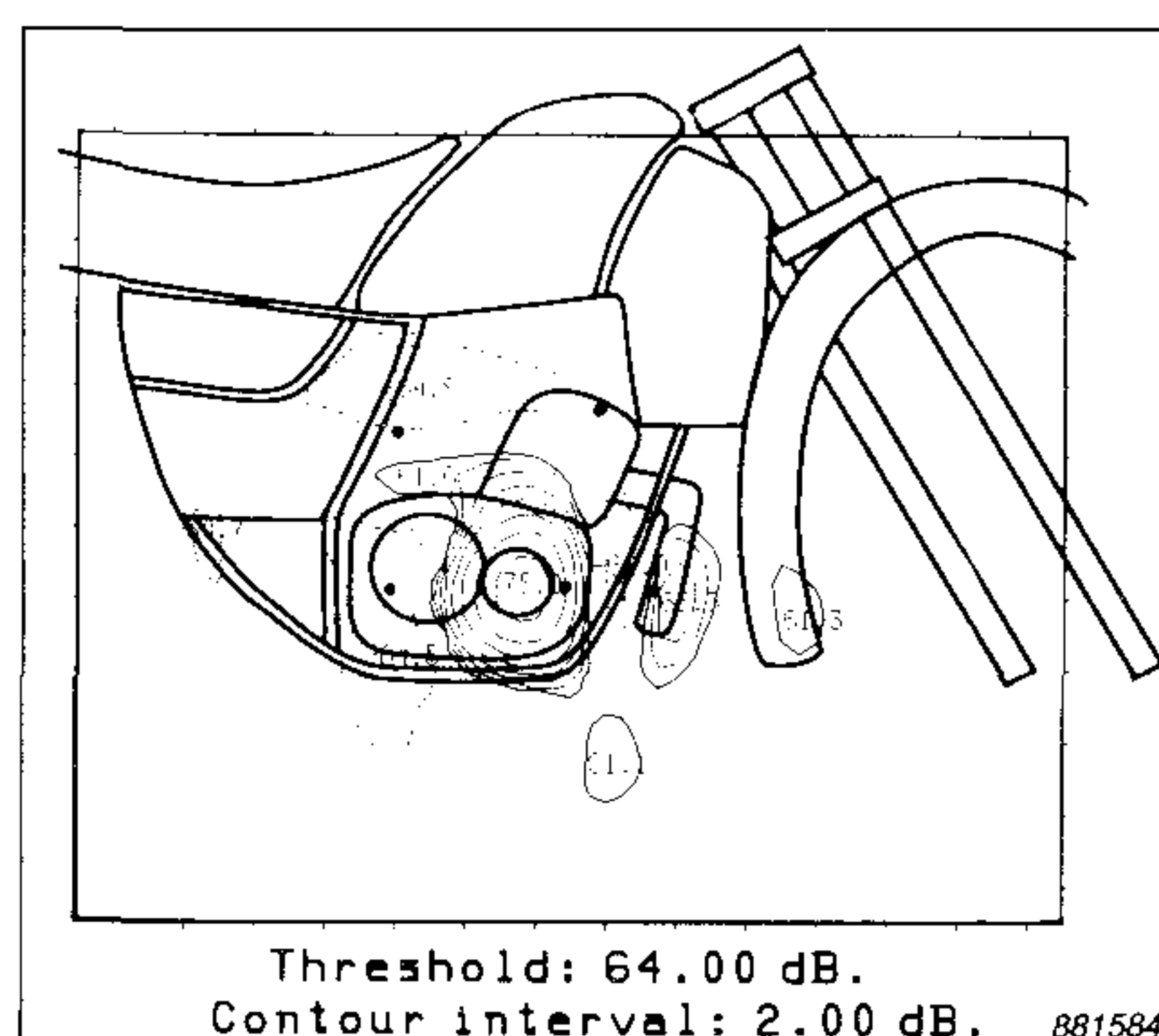

Fig. 6. Reactive intensity plot. 1600 Hz twelfth octave band

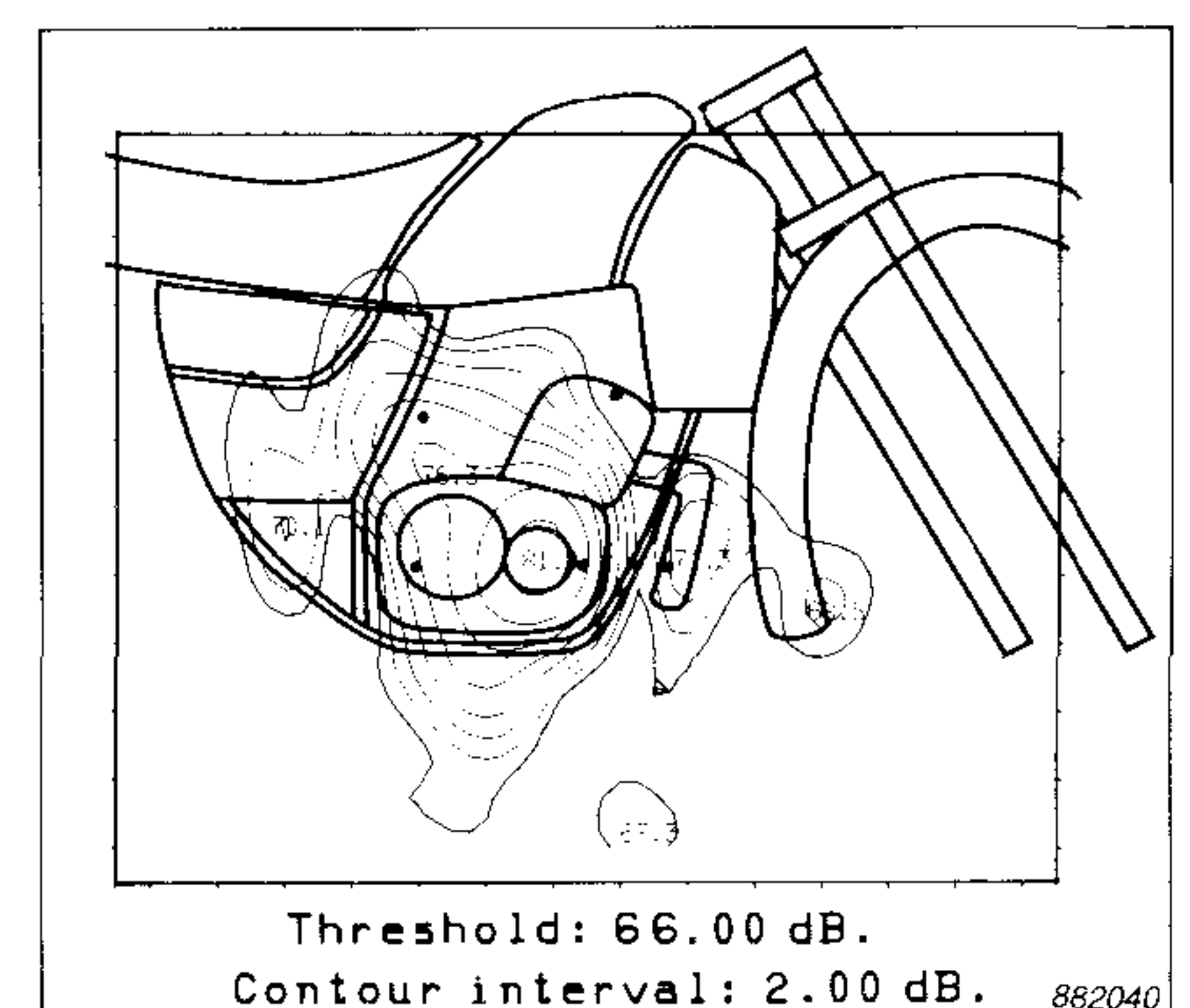

Fig. 7. Pressure contour plot. 1600 Hz twelfth octave band



WORLD HEADQUARTERS: DK-2850 Nærum · Denmark · Telephone: +45 280 05 00 · Telex: 37316 bruka dk · Fax: +45 280 14 05

Australia (02) 450-2066 · Austria 02235/7550*0 · Belgium 02-242-97 45 · Brazil (011) 246-8149/246-8166 · Canada (514) 695-8225 · Finland (90) 80 17 044
France (1) 64 57 20 10 · Federal Republic of Germany (04106) 4055 · Great Britain (01) 954-2366 · Holland 03402-39994 · Hong Kong 5-487486 · Italy (02) 52 44 141
Japan 03-438-0761 · Republic of Korea (02) 554-0605 · Norway 02-78 70 96 · Portugal (1) 65 92 56/65 92 80 · Singapore 225 8533 · Spain (91) 268 10 00
Sweden (08) 711 27 30 · Switzerland (042) 65 11 61 · Taiwan (02) 713 9303 · USA (508) 481-7000 · Local representatives and service organisations world-wide